

Operating Instructions

N 05300.1.05

N 05300.1.06

N 05300.1.16

Frequency controller for vibratory feeders

Technical Information for the User

This description contains the necessary information for the correct application of the product described below. It is intended for use by technically qualified personal.

Qualified personnel are persons who, because of their training, experience and position as well as their knowledge of appropriate standards, regulations, health and safety requirements and working conditions, are authorised to be responsible for the safety of the equipment, at all times, whilst carrying out their normal duties and are therefore aware of, and can report, possible hazards (Definition of qualified employees according to IEC 364)

Safety Instructions

The following instructions are provided for the personal safety of operators and also for the protection of the described product and connected equipment.

**Warning!**

Hazardous Voltage

Failure to observe can kill, cause serious injury or damage

- Isolate from mains before installation or dismantling work, as well as for fuse changes or post installation modifications.
- Observe the prescribed accident prevention and safety rules for the specific application.
- Before putting into operation check if the rated voltage for the unit conforms with the local supply voltage.
- Emergency stop devices must be provided for all applications. Operation of the emergency stop must inhibit any further uncontrolled operation.
- **The electrical connecting terminals must be covered!**
- **Earth bonding must be tested for integrity after installation.**

Specified Use

The units described herein are electrical controllers for installation in industrial plant. They are designed for controlling vibratory feeders.

Contents

Technical Information for the User	2
1.0 General	4
2.0 Function	4
2.1 Track Control (only N 50300.1.06, N 50300.1.16)	4
2.2 Operating with two speeds (2 set points for coarse/fine switching)	5
2.3 Control inputs and output	5
2.4 Displays	5
3.0 Constructions	5
3.1 Ancillaries	5
4.0 Technical Data	6
5.0 Ordering codes	6
5.1 Ordering codes (Acceleration sensor)	6
6.0 Declaration of Conformity	6
7.0 Settings	7
8.0 Control Elements	8
8.1 Settings	8
9.0 Commission	9
9.1 Preliminary steps	9
9.2 Operating frequency of the feeder coil	9
9.3 Measurement of the output voltage and current	9
9.4 Set point zero setting	9
10.0 Setting Instructions	10
10.1 User adjustment of throughput	10
10.2 Configuration of the feed system	10
10.2.1 Feeder settings	10
10.2.2 Track Control (only: N 50300.1.06, N 50300.1.16)	10
10.2.3 Setpoint source	11
10.2.4 Regulation Mode (only: N 05300.1.16)	11
10.2.4.1 Instructions for using regulation mode	12
10.2.4.2 Mounting the accelerometer	12
10.2.4.3 Relationship between acceleration and amplitude	14
10.2.4.4 Instructions for setting up the controller in regulation mode	14
10.2.4.5 Determining the resonant frequency	14
10.2.4.6 Optimising controller in regulation mode	15
10.2.4.7 Display Indications (Regulation mode only)	15
10.2.5 Saving current parameter settings (User settings)	16
10.2.6 Re-instate factory or user settings	16
10.2.7 Hide parameter menus	16
11.0 Fault messages	16
12.0 Connections for enclosed version	17
13.0 Dimensions	18
13.1 Dimensions Accelerometer	19

1.0 General

The N 05 300 range comprises special, adaptable controllers for use with vibratory feeders. The units generate an output frequency, to drive feeders, that is independent of mains frequency and so exact tuning with springs is not necessary. The feeders also run quieter because of the sinusoidal output signal. The adjusted output frequency corresponds to the mechanical vibrating frequency of the feed system. The optimum frequency setting for a feeder can be determined manually or automatically in regulation mode.

Depending on the version, the controller can be used in regulation mode, working in conjunction with an accelerometer fitted to the feeder, to operate at resonant frequency. In this way a constant component feed rate that is unaffected by load changes can be achieved. In regulation mode the vibrating frequency is also dynamically adjusted to compensate for load changes. In normal operating mode the feeder remains constant at the set frequency. In both operating modes the feeder throughput is determined by the output voltage level.

Notable Features:

- Adjustable output frequency, independent of mains frequency
- Constant feeder throughput irrespective of mains fluctuations
- Track control
- Regulation control, automatic frequency search (resonance)
- On/Off status relay

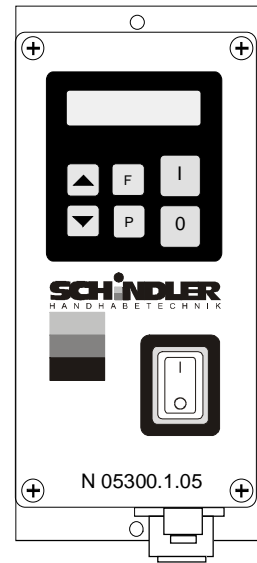

2.0 Function

The unit is set up by using the touch panel on the front plate (buttons and LED display). All settings can be made by using the touch panel and a series of menus. The various parameters can be selected by entering operator codes. A fuller description of the parameters can be found in the section on settings. Alternatively, the feeder throughput can be adjusted by using an external potentiometer, an external voltage signal 0...10 V, DC or a current signal 0(4)...20 mA (the chosen option must be selected in menu 003). A relay with potential free contacts is provided for feeder status indication and this operates in conjunction with the feeder enable signal. Terminals for these contacts can be found inside the controller.

During normal operation the set point is displayed as a percentage in the LED window. In the programming mode the selected dimension, as described in the setting up instructions, is shown. Changed settings can be stored by leaving the programming mode or automatically saved by not pressing a key for a period of 60 seconds.

2.1 Track Control (only N 50300.1.06, N 50300.1.16)

The output can be switched ON and OFF from a track component sensor, using internal, adjustable time delays (ton and tuff).

The queue of components rises above and drops below the track sensor position. The controller output switches on when the sensor cannot detect product and a switch-on time delay has elapsed.

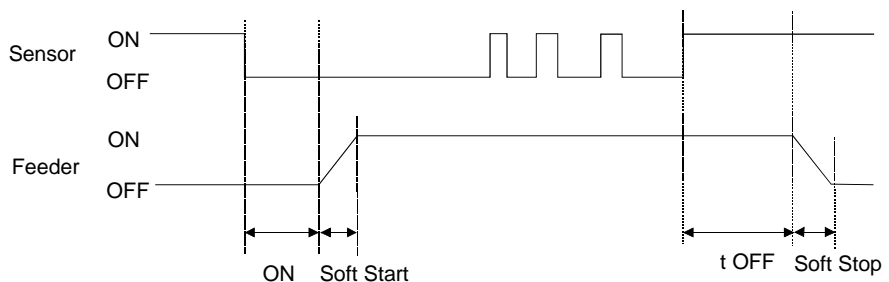

The output is switched off when product is detected and a switch-off time delay has elapsed (FULL displayed in the LED window). Gaps in the product feed cause resetting of the time delay. The time will always be precise from the last or first component, respectively. The ON and OFF time delays are set in the programming menu. The first decimal point in the display blinks to indicate that an internal timer is running.

An additional "Sensor-Time-out" timer is started when the feeder switches on. This can be set (1...240 sec.) to switch off the feeder if no product is sensed in the time out period. The status relay indicates that the feeder is not running and the LED window displays ERROR and SE alternately. This function is optional and must be selected in the Track Settings Menu with function EE = 1.

2.2 Operating with two speeds (2 set points for coarse/fine switching)

Switching is achieved by using the sensor input, instead of using it for track control. The second set point is activated, immediately, by applying a 24 V signal
(The track control function is invalid)

2.3 Control inputs and output

Enable input: External switch or voltage signal 24 V, DC

External set point: 0...10 V, DC / 0(4)...20 mA, Potentiometer 10 kR

Sensor for track control: 24 V, DC (PNP)

Control output:

Status-Relay Relay contact 250 V/1 A (changeover). Relay closes when the feeder is running – the relay opens when there is no enable signal or a fault displayed.

2.4 Displays

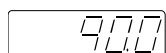

Normal Mode: The throughput set point is displayed

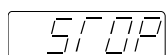

Output switched off using the `0` button

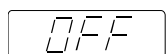

Unit inhibited by the enable input

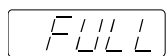

Output switched off by the track control sensor

3.0 Constructions

Units are available as stand-alone or panel-mounted versions

3.1 Ancillaries

- Mains switch
- Operating and display panel
- Mains cable
- Output cable or output socket for connecting feeder
- Standard sensor socket suitable for 24 V, DC Sensors with a PNP output.

The blind stopper must be replaced with an additional cable gland when the status relay is used.

4.0 Technical Data

Model Name	N 05300.1.05	N 05300.1.06	N 05300.1.16
Mains supply	110 V, 240 V +/- 10 %, 50/60 Hz		
Output voltage	0...95 V, 0...205 V		
Output frequency	8 – 70 Hz		
Output current	3 A	3 A	6 A
Recommended Protection	10 A Rating MCB Type `C`		
Enable	24V, DC Input (contact with internal 24V reference)		
Status relay	Changeover contacts, 250V, 1A		
Sensor supply	24 V, DC, 100 mA		
Sensor type	PNP-, Output		
Operating Temp	0...+45 °C		
Storage Temp	-10...+80 °C		
Altitude	1000 m 1 % dreading for each additional 100 m		

***There is a current surge caused by internal capacitors, when a unit is first switched on. This can cause false tripping particularly when several units are switched on simultaneously. Therefore it is important to use correctly rated protection devices with the recommended characteristics**

5.0 Ordering codes

Model	ID No.	Construction
N 05300.1.05	616841	3 A, Enclosed construction IP 54
N 05300.1.06	616842	3 A, Enclosed construction IP 54 with track control
N 05300.1.16	616896	6 A, Enclosed construction IP 54 with track control and amplitude regulation

5.1 Ordering codes (Acceleration sensor)

Description	ID No.	Version
N 05300.1.15 SWS0002	45772	SW72 Acceleration sensor, IP54, Connector M12, Cable length 2m
N 05300.1.15 SWS0005	45773	SW73 Acceleration sensor, IP54, Connector M12, Cable length 5m
N 05300.1.15 SWS0010	45774	SW74 Acceleration sensor, IP54, Connector M12, Cable length 10m
N 05300.1.15 SWS0015	45775	SW75 Acceleration sensor, IP54 Connector M12, Cable length 15m

6.0 Declaration of Conformity

We declare that these products conform with the following standards:

2014/30/EU EMC EN 61000-6-4:2007 +A1:2011; EN 61000-6-2:2005
 2014/35/EU LVD EN 50178:1997
 2011/65/EU RoHs



7.0 Settings

After checking the correct operation of the controller in conjunction with the vibratory feed system it is advisable to restrict the user to feeder throughput settings only.

Setting the feeder throughput:

Press the P key twice and adjust the throughput with the cursor keys (Code C. 000).

Parameter:		Code	Factory Setting	Entry Code
Vibratory Feeder				
• Amplitude (feeder throughput)	0...100 %	A.	0 %	000, 002

The following adjustments are available for setting up the feeder system

Parameter:		Code	Factory Setting	Entry Code
Vibratory Feeder				
• Amplitude (feeder throughput)	0...100 %	A.	0 %	000, 002, 096
• Max adjustment limit (Umax)	50...100 %	P.	100 %	096, 008
• Vibrating frequency	8... 70 Hz	F.	70 Hz	096, 008
• Soft start ramp time	0...4 Sec	/.	0,1 Se	096
• Soft stop ramp time	0...4 Sec	\.	0,1 Sec	096
• Connection to external set point	0 / 1	E.S.P.	0	003
• Set point 0(4)...20 mA	0 / 1	4.20	0	003
• Potentiometer	0 / 1	POT.	0	003
• Coarse / Fine Control	0 / 1	S.P.2.	0	003
• Enable function invert	0 / 1	-En.	0	003
Regulation mode (with accelerometer) (only: N 05300.1.16)				
• Enable regulation mode	0 / 1	ACC.	0	008
• Proportional characteristic (regulation param.)	0...100	P.A.	40	008
• Integral characteristic (regulation param.)	0...5	I.A.	0	008
• Automatic frequency control	0 / 1	A.F.C.	0	008
• Start automatic frequency search		A.F.S.		008
Track control (only N 50300.1.06, N 50300.1.16)				
• Switch ON time delay	0...15 Sec	I.	5 Sec	167
• Switch OFF time delay	0...15 Sec.	O.	5 Sec.	167
• Sensor function invert	PNP / PNP inverse	-SE.	PNP	167
• Sensor Time-out delay	30...240 Sec	E.E.	not active	167
• Sensor Time-out function active	0 / 1	E.	0	167
Service				
• Save current settings		PUSH.		143
• Return to factory settings		FAC.		210
• Return to user settings		US.PA.		210
• Hide programming menus	0 / 1	Hd.C.	0	117
• Display software version				001

8.0 Control Elements

8.1 Settings

The six buttons and a LED display found in the front panel, are used for operating and setting up the unit. All operating methods and adjustable parameters can be set up through this panel.

The “I” and “O” buttons are used for switching the unit ON and OFF, however, these do not provide mains isolation, they simply inhibit the power semiconductors

The “P”, “F” and “Cursor Buttons” are used for parameter adjustment. Parameters are set by using menu controls which are called up by entering operator codes. The functions are described in greater detail in the section on setting instructions.

The display value can be increased or decreased by units, or tenths of units, by a short press of the cursor buttons. Holding the buttons down will cause the display to change in units of ten.

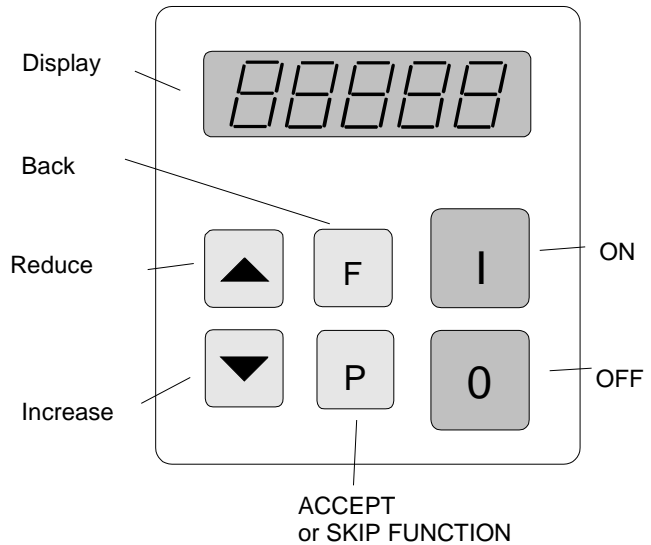

To prevent accidental or unauthorized adjustment the adjustment parameters, in the user menus, are protected. A code must be entered to open the user menus. There are different pass codes for each function group.

Setting adjustments are automatically saved upon leaving the programming mode or if no button is pressed for a period of 100 seconds.

All setting routines are commenced by pressing the programming button “P”. The following diagram should clarify the sequence in which keys are pressed:

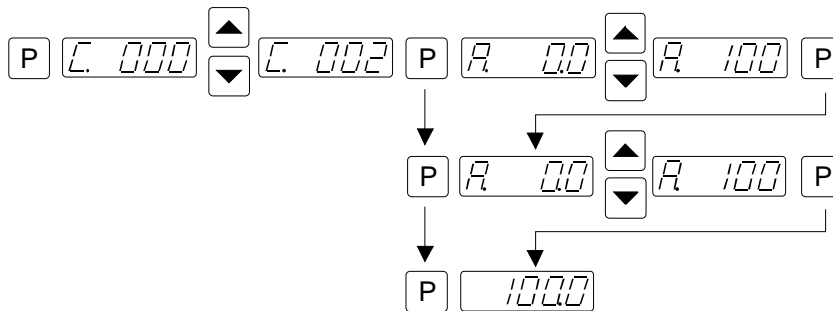

1. Press the “P” key.
2. Select the code number with the cursor keys.
3. Press the “P” key. This displays the first menu point. The required menu point can be found by repeatedly pressing the “P” key (scrolling).
4. The value in the menu point can be changed with the cursor keys.
5. Scroll to the next menu point or to the end of the menu, which returns the display to the set point value, by pressing the “P” key. To exit the menu and return back to the normal display, quickly, depress the “P” key for 5 seconds.
6. To return back to the previous position in the menu, press the “F” key.

9.0 Commission

9.1 Preliminary steps

- Check that the unit is correct for the local mains supply (rating plate information) and that it is correctly rated for the feed system.
- Connect the controller according to the connection diagram
- Adjust the set point to zero
- Close enable (when used)

The unit is now ready to operate and can be switched on (mains, enable).



Important:

Using the control units described in this document, it is possible to adjust the feed system so that it runs at resonance. In this condition it is possible to obtain excessive output for a very low set point setting. Therefore extreme care should be taken to avoid causing damage to the drive coil, through hammering.

In practice it is not possible to run at resonant frequency without accelerometer feedback because the system would be unstable and uncontrollable. The system must be set safely off resonance ie either above or below the natural frequency.

Resonant frequency: Depending on the spring and mass design of the feeder system it is possible to have resonance at more than one frequency. These additional resonance points are multiples of the main frequency. For this reason in critical situations it is possible that the automatic frequency search will not find true resonance and in such cases the natural frequency must be determined manually.

9.2 Operating frequency of the feeder coil

It is possible that the current flowing through the coil will increase for a small frequency adjustment. and so this should be checked with a true RMS instrument for each new application as well as monitoring the coil for heat build-up.

The coil should be designed for the correct operating frequency to prevent excessive current draw and the consequential overloading of the coil.

9.3 Measurement of the output voltage and current

The voltage and current cannot be measured with a regular instrument because the controller output uses an electronic inverter with a pulse width modulation signal. An effective measuring instrument such as a moving iron meter (analog) must be used. It is recommended that an analog instrument is used rather than an electronic multi-meter which will give a misleading reading.

9.4 Set point zero setting

Should the unit produce a condition that is not healthy, during setting up e.g. hammering of the feeder, or too high a current draw, prevented by quickly switching off the supply, then the output can be returned to zero, immediately, the next time the mains supply is switched on by using the following procedure:-

Press the down  cursor and hold whilst powering up using the mains switch.

10.0 Setting Instructions

10.1 User adjustment of throughput

Code 000 Set point

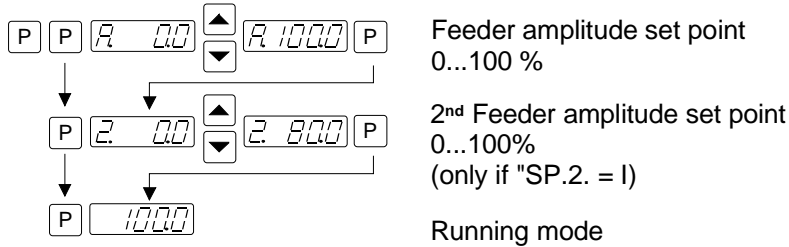

An additional set point menu can be found in C002

10.2 Configuration of the feed system

10.2.1 Feeder settings

Code 096

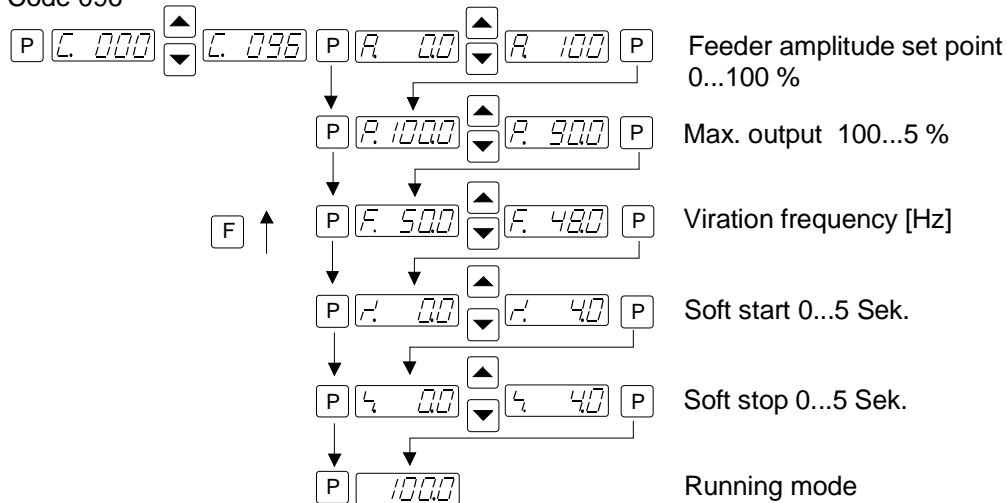

10.2.2 Track Control (only: N 50300.1.06, N 50300.1.16)

Code 167

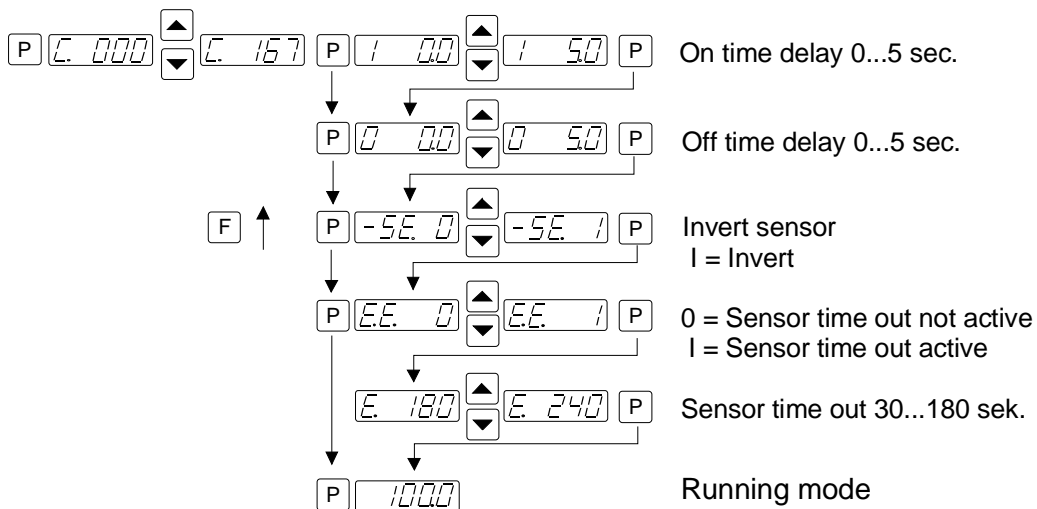

10.2.3 Setpoint source

Code C. 003

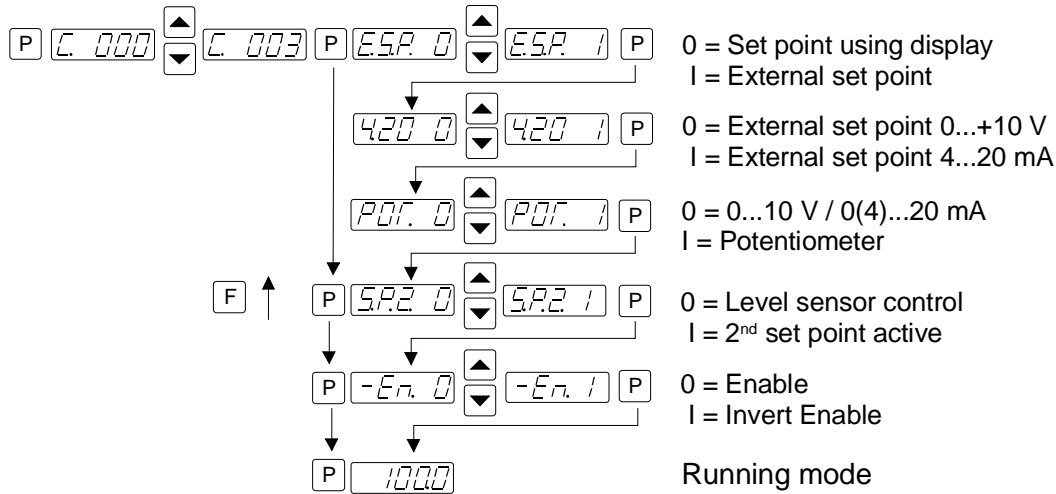

10.2.4 Regulation Mode (only: N 05300.1.16)

Code C. 008

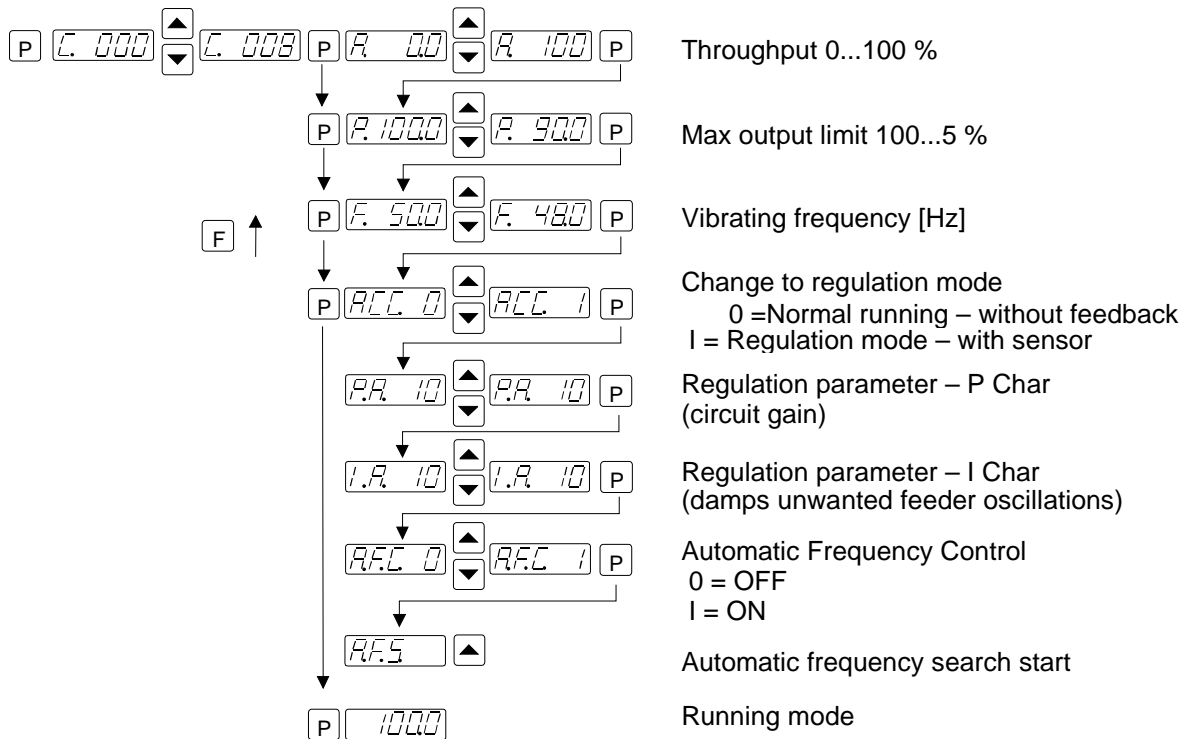

10.2.4.1 Instructions for using regulation mode

- An accelerometer must be fitted to the vibratory feeder in order to run in regulation mode.
- All vibration signals, that are picked up by the accelerometer, are used by the regulator circuit. Stray signals generated by neighbouring machinery, a flimsy accelerometer mounting, or an unstable support frame, can cause incorrect regulation to occur. It is especially important to ensure that there are no external influences, of this type, during the automatic frequency search routine.
- Resonant frequencies: It is possible to have several vibrating frequencies, where resonance occurs, depending on the springing and masses of the system. The additional resonant points are at multiples of the dominant resonant frequency. Under extreme circumstances the automatic frequency search may be unable to differentiate between these frequencies and so in these instances the frequency must be set manually.

10.2.4.2 Mounting the accelerometer

The accelerometer should generate signals for the movement and acceleration of the feeder, which are fed back to the regulator circuit of the control unit. Therefore it is very important that no other extraneous vibration signals are picked up by the sensor

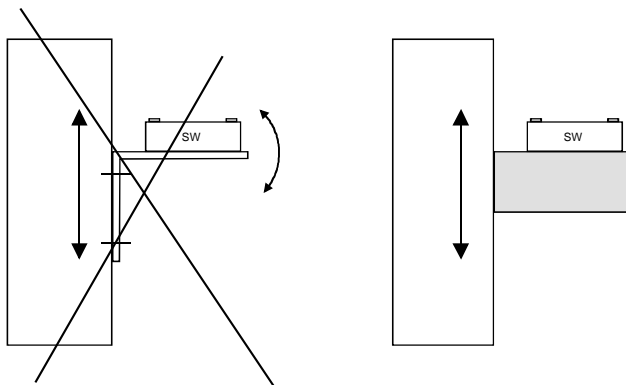

The sensor should be positioned so that it moves in the same direction as the feeder, ideally in the same plane as the springs, and it should be fitted on a solid block that will not generate vibration signals.

The sensor cable need to be fixed with a cable clamp to avoid damage of the cable.

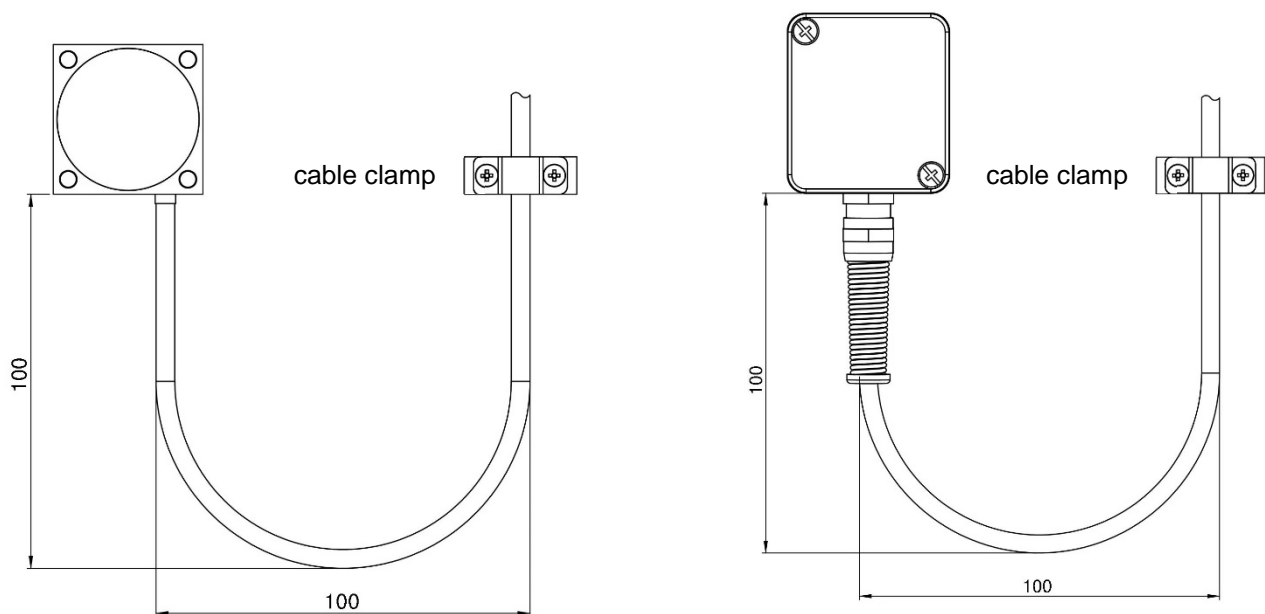

In regulation mode the magnitude of the output signal has a direct affect on the maximum amplitude of the feeder.

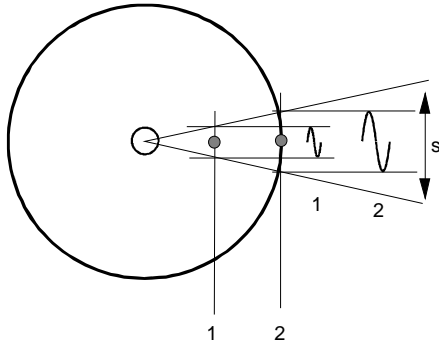

On bowl feeders it is advisable to fit the sensor as near as possible to the outside diameter and in this position it will be subjected to the greatest movement

The control range of the set point will be considerably reduced when the sensor signal is weak.

s = deflection

Mounting position 1 = small deflection
Mounting position 2 = large deflection

Bowl feeder example

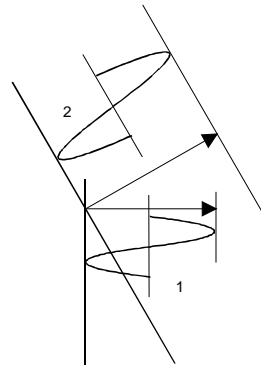
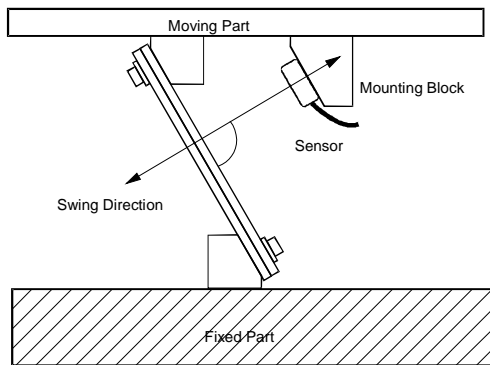

1. small amplitude because sensor is mounted vertically.
2. larger amplitude because sensor is mounted in the same plane as the springs.

Linear feeder example

The controller, together with the sensor fitted on the feeder, produce a feed back loop, whereby the signal generated from the sensor determines the control range of the set point i.e. the regulator controls the feeder so that the effective value (feeder power or intensity of vibration) relates to the provided set point value. Because the effective value is dependent on the feeder (frequency, acceleration and amplitude) and in addition depends on the mounting position of the sensor, the regulator must be adapted to suit the output control range.

This is achieved by using the parameter P in Menu C 008. The measured sensor signal range is adjusted by changing this value. In most instances a value of less than 100 must be entered, so that the set point can reach 100% or can go as high as possible.

When it is not possible to achieve an acceptable range the accelerometer should be mounted in the location which gives the greatest movement (see the bowl feeder example).

The importance of scaling this value is demonstrated when, for example, a feeder takes a very long time to ramp up, after it has been switched on.

10.2.4.3 Relationship between acceleration and amplitude

The sensor measures the momentary acceleration of the feeder. It generates a sinusoidal output voltage signal. The acceleration gets higher as the frequency increases. The sensor signal is greater for a higher frequency and lower amplitude than for a low frequency with a higher amplitude.

<p>Acceleration</p> $a = \omega^2 s \quad \text{where} \quad \omega = 2 \pi f$ <p>In practice the acceleration is influenced by gravitational force and the applied amplitude is measured in mm and so this gives the following formula:</p> $a[g] = \frac{2^2 \pi^2 f^2 [Hz]^2 s_n [mm]}{9,81 \cdot 2 \cdot 10^3} = \frac{f^2 [Hz]^2 s_n [mm]}{497}$ <p>a[g] = Acceleration (with respect to gravitational acceleration of 9.81 m/s²) S_n[mm] = Applied amplitude</p>	<p>In practice where 497 is approximated to 500 this gives, for example:</p> <p>1. Vibrating frequency 50Hz Amplitude 3mm</p> $a = \frac{50^2 \cdot 3}{\approx 500} = 15 g$ <p>Or</p> <p>2. Vibrating frequency 33Hz Amplitude 5mm</p> $a = \frac{33^2 \cdot 5}{\approx 500} = 10,89g$
---	---

Using an accelerometer with an output signal of 0.3 V/g the sensor generates a peak voltage of 4.5V for a peak acceleration of 15g (Example 1), corresponding to a 3.18V RMS value.

Example 1: => 15 g => 4,5 V => 3,18 V_{eff}.

Example 2: => 11 g => 3,3 V => 2,33 V_{eff}.

Because of the vastly different acceleration values of various feeders there is a big difference in the feedback signals, which makes scaling necessary.

10.2.4.4 Instructions for setting up the controller in regulation mode

- Connect control unit
- Install sensor and connect to controller

10.2.4.5 Determining the resonant frequency

Manual setting of the vibrating frequency

It is essential that the output frequency is adjusted with the set point set at a low frequency, otherwise on hitting the resonant frequency it is possible to achieve a high amplitude with a low output voltage. An analog, effective value, current indicating unit (moving iron meter) must be connected into the output circuit. Resonant frequency has been reached when there is a maximum amplitude for a minimum output current.

Automatic frequency search

Change the set point to zero.

Select regulation mode (Menu C 008, Parameter ACC = 1)

The optimum frequency of the feeder is found, automatically, by initiating the frequency search (Menu C 008, Parameter A.F.S.). When this has been found the controller resets the set point back to its original value (0).

10.2.4.6 Optimising controller in regulation mode

Setting the control range

1. In Menu C. 096 set Parameter `P` (Max Limit) to 10 %
2. Set `A` (Feeder throughput) to 100%
3. Increase `P` from 10% until the required maximum feeder throughput is achieved

The full adjustment range `A` of 0...100% can be used

Optimising regulation: For unwanted feeder oscillation (hunting) or inadequate feedback regulation for load changes

The response of the regulation circuit can be adjusted in menu C008 using the parameter `PA` (Proportional characteristic or circuit gain) and `IA` (Integral characteristic)

In menu C008 reduce `PA` until the oscillations are reduced

Parameter `IA` should be set to `0` or the lowest possible setting

10.2.4.7 Display Indications (Regulation mode only)

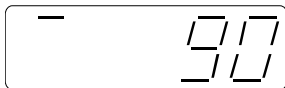

Maximum output of the feeder has been reached
 The feedback signal from the sensor (acceleration) is too low relative to the set point
 Reduce parameter `P` in menu C008



The feedback signal from the sensor (acceleration) is too high.



Rapidly changing display:
 Regulation altering without control – feeder surging
 Reduce parameter `PA` in menu C008



10.2.5 Saving current parameter settings (User settings)

Code C. 143

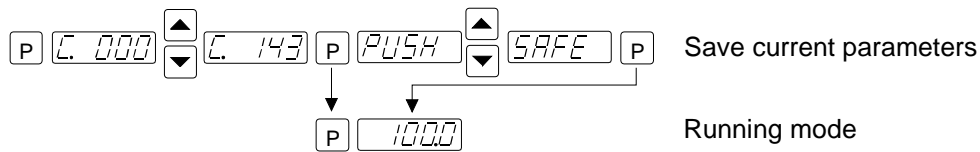

10.2.6 Re-instate factory or user settings

Code C. 210

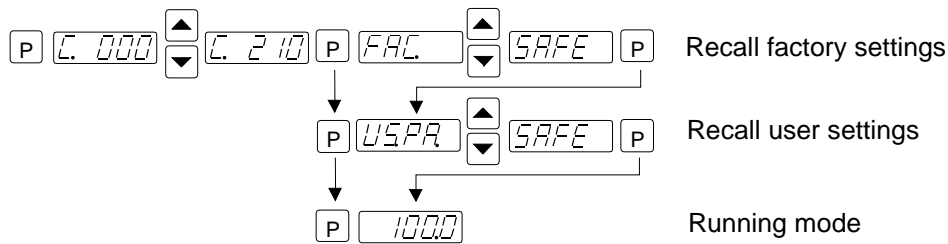

10.2.7 Hide parameter menus

Code C. 117

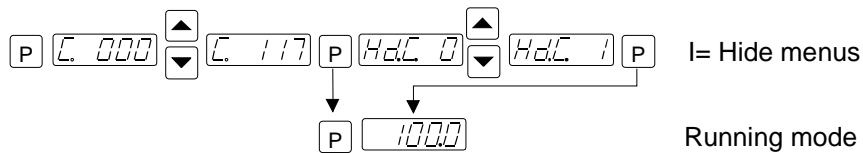

11.0 Fault messages

In an error condition the fault code is displayed in conjunction with a flashing `ERROR` message

Overload Limit Error OL

Short circuit Error OC

Mains voltage too high or
Back EMF from feeder coil Error OU

Sensor Time Out
Sensor time-out function time
delay has been exceeded. Error SE

The unit can be reset by pressing the `P` key

12.0 Connections for enclosed version

Internal connections

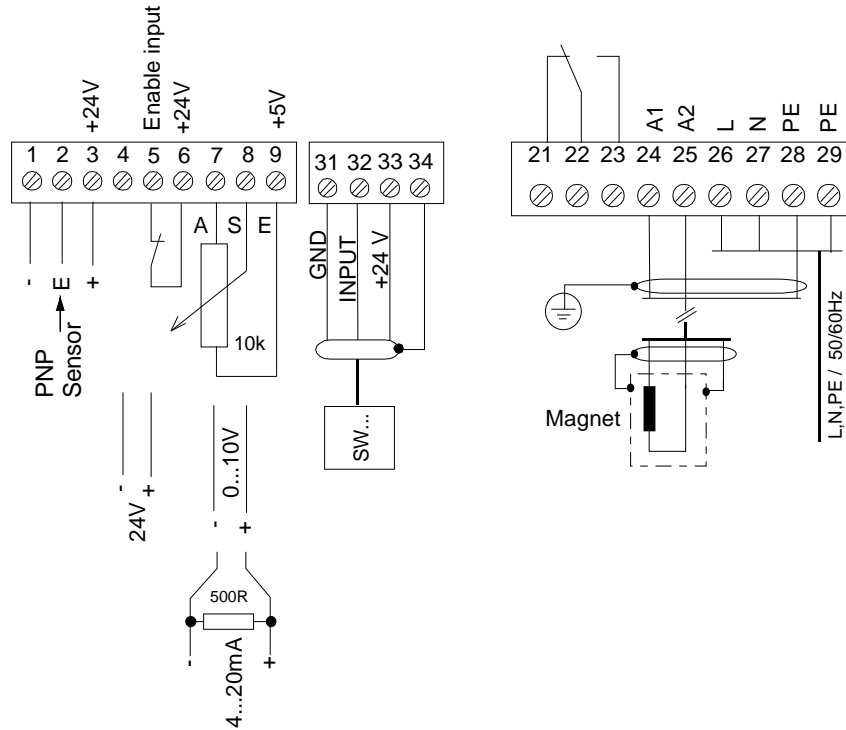

! Set menu - code C 003 „POT.“ = I for using external Potentiometer

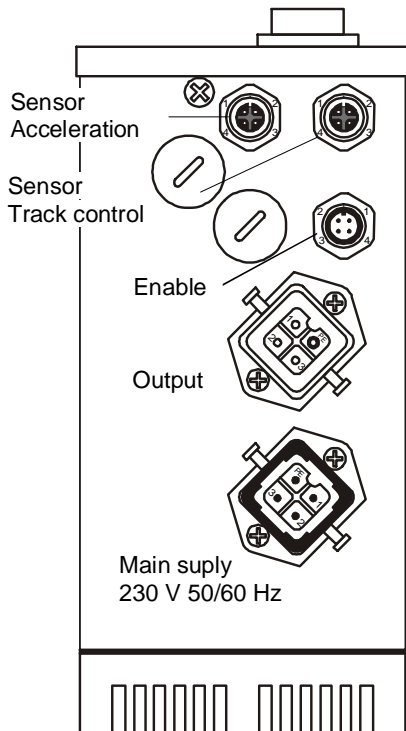

View from outside connector

Sensor socket Accelerometer

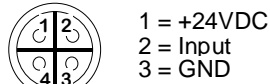

- 1 = +24VDC
- 2 = Input
- 3 = GND

Sensorsocket Track control



- 1 = +24VDC Ausgang
- 3 = GND
- 4 = Eingang Füllstand

Sensor socket Enable



- 1 = +24VDC (internal)
- 3 = GND (external)
- 4 = Input Enable (internal + external)

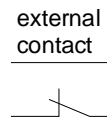

external contact

external voltage

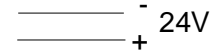

Output socket

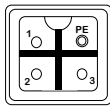

- 1 = A1
- 2 = A2
- 3 = Screen
- 4 = PE

Main supply input

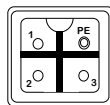

- 1 = L
- 2 = N
- 4 = PE

To comply with EMC requirements the output cable to the feeder must be screened.

13.0 Dimensions

Enclosed version

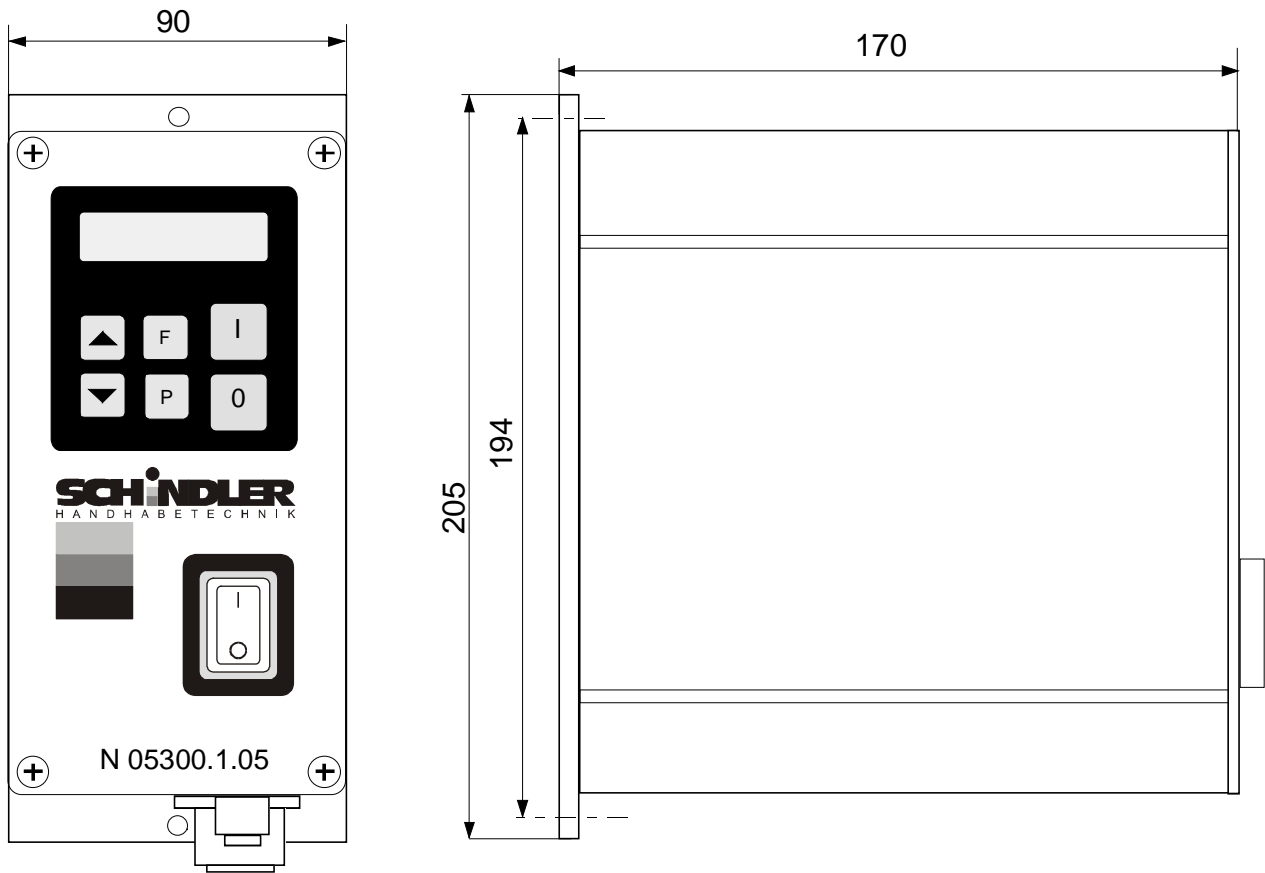

13.1 Dimensions Accelerometer

